



DFB19E NEUTRALIZER

Model	DFB19E
Model Description	Neutralizer (Drain Filter)
Applicable Models	CP5WN, CP10WN, NNCP096J, NNCP120J, NNCP144JN, NNCP168JN, NFPC168JN, YNZP710H1NB, YNZP850H1NB
Dimensions	9.5 x 5.3 x 7.1 inches (240 x 134 x 181 mm)
Weight	Inside Filling: 4.4 lb (2 kg)
Materials	Cover & Case: Resin



Dimensional Drawings:
Units: Inches [mm]

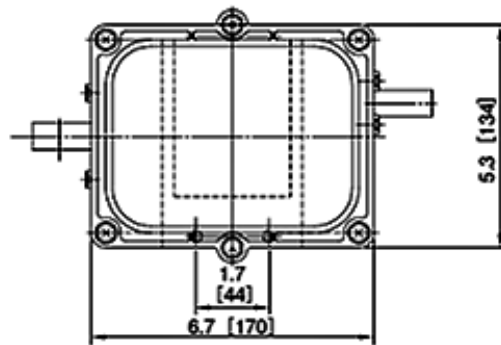

9	O-ring 1AG150	1		
8	O-ring 1AG25	2		
7	Bolt (+ 6 holes x20)	6		
6	Bolt (+ 6 holes x12)	4		
5	Pipe (drain)	2		
4	Filling (drain filter)	1	1	2kg x1
3	Diaphragm (filling)	1		
2	Cover (drain filter)	1	1	
1	Case (drain filter)	1	3	
Stock Number	Name	Number of Items	Installation Order	Notes

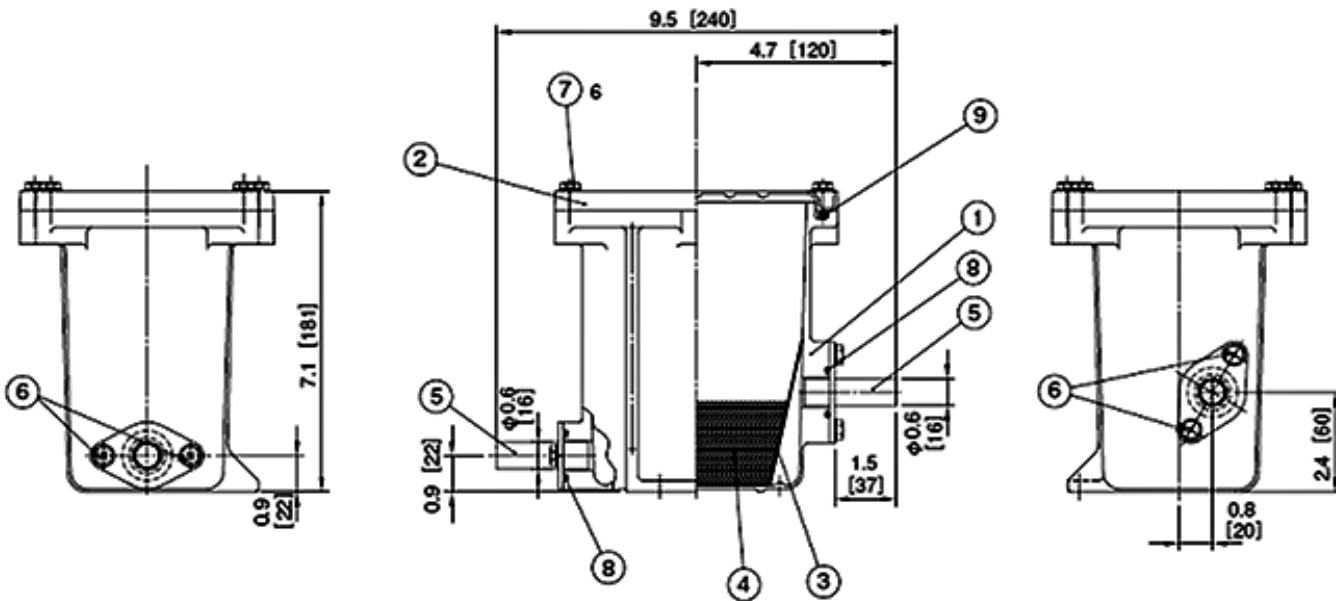

Notes:

Tightening torque 1.96-2.35 N • m (20-24 kgf • cm)

An air tightness test with air pressure of 2.9 psi (.02 MPa) must be conducted after installment.

NOTE: Due to YANMAR's ongoing commitment to quality, specifications, ratings and dimensions subject to change without notice. Improper installation, adjustment, alteration, service or maintenance can cause property damage or personal injury. Installation and service must be in accordance with current specifications, ratings and dimensions and be performed by a qualified installer and servicing agency.