

## 2.Exhaust pipe extension joint : EKC10W

### 1) Purpose

Connect the CP exhaust outlet and exhaust pipe, which needs to be longer in order to install CP inside of the building.

### 2) Specification

Model	EKC10W
Dimension	Height : 11.3inch (288mm)
Weight	3.1lb. (1.4kg)
Pipe Diameter at Connection Point	1·1/2" (40A)
Materials	SUS304, SUS316L

### 3) Outline drawing

• Outline Drawing

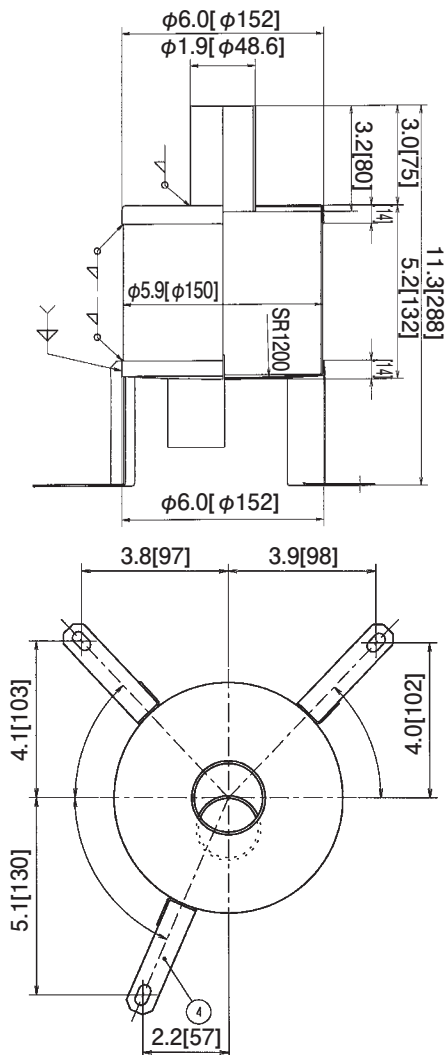

• Installation Drawing

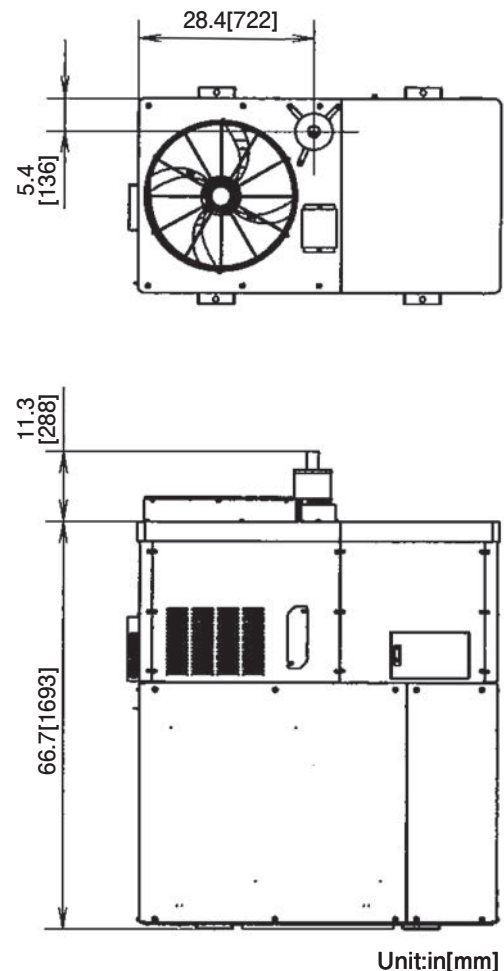

### 4) Others

- Install the Exhaust Pipe Extension Kit following the instructions of the attached installation work manual.
- Install Drain Filter DFB19E since the amount of exhaust drain water increases as the length of the exhaust pipe becomes longer.